

EMCO

UMILL 630

**Universal machining center
for 5-axis machining**



COMPACT UNIVERSAL MACHINING CENTER

Equipped with a front table support, the UMILL 630 – our universal and vertical CNC machining center – is capable of milling parts featuring an edge size of 445 x 445 x 400 mm and a weight of up to 200 kg using highly precise and highly efficient, simultaneous 5-axis machining. Its compact design in cast iron and welded steel, optimised by FEM analysis, with direct drives in X-Y-Z and standard linear scales among its features, it guarantees the maximum in rigidity and thermosymmetry, the highest precision and an excellent surface quality of the workpiece. With its important technological and architectural innovations, the UMILL 630 creates optimum conditions for high-quality production.



Fan (Brass)

1 MACHINE BASE

- / The machine base consists of welded steel construction stabilised through heat treatment, optimised with FEM analysis
- / X, Y slide and Z-axis are cast iron
- / Linear scales in X-Y-Z as standard



2 WORK TABLE

- / Swivel-rotary table with torque motors on the B- and C-axes, special worm gear with two drive motors in the B-axis
- / Swivel range of the B-axis: +/- 100°
- / Front support included in the standard scope of supply
- / Both axes with absolute value sensor

3 SPINDLE

- / Motor spindle: 15000 / 24000 rpm



/ Özgün Selim
Product Sales Manager Milling

“By using high-quality European components, we focus on both the excellent technical values and the very high availability of the machine. What is more, our customer service – which has become well established on the market – is highly appreciated by our customers and immediately available at fair conditions.”



4 ERGONOMIC OPERATING PANEL

- / Available with Sinumerik ONE or Heidenhain TNC 640
- / Height adjustable 90° swivelling operating panel
- / EMCONNECT for Sinumerik ONE

5 TOOL CHANGER

- / Tool changer with 30 tool stations
- / Tool changer with 60/90 tool stations available as option

6 CHIP REMOVAL

- / The chip removal can be handled by an optionally available hinge-type chip conveyer

TECHNICAL HIGHLIGHTS

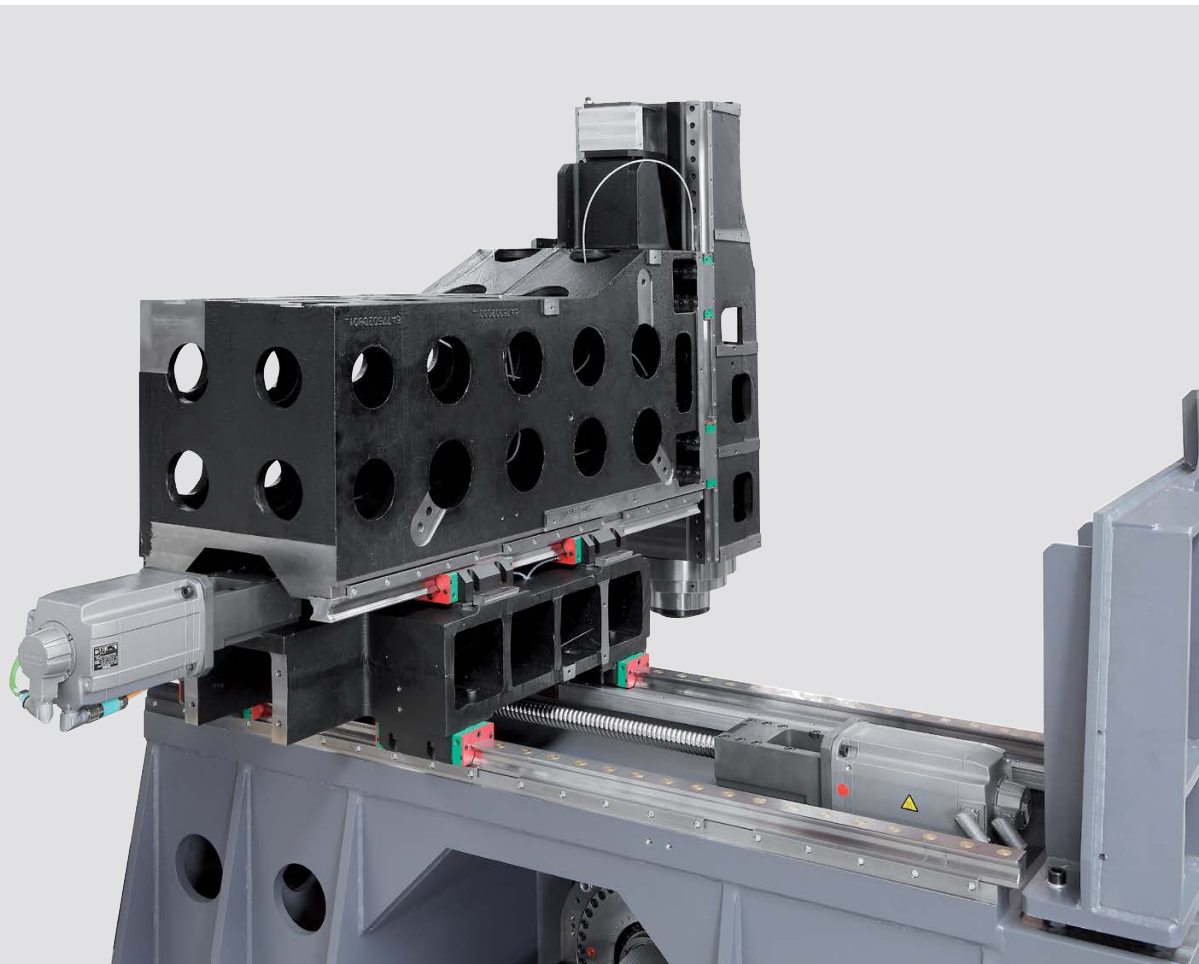

DIRECT DRIVES

The direct drives in X-, Y- and Z-axis allow to reach high performances in acceleration (6 m/s^2) and in rapid motion speeds (50 m/min). In addition, this ensures maximum precision and high dynamics.



TOOL CHANGER

The tool changer of the Umill 630 is a drum magazine for 30 tools. A tool magazine with 60/90 tool stations is available as option. The tools are managed according to the variable tool station coding principle (random), which means that tools are always deposited in the first free magazine station for time reasons. Other tool changer stations are available upon request.



SWIVEL-ROTARY TABLE

The swivel-rotary table has a large clamping area of 630 x 500 mm and can bear loads of up to 300 kg thanks to the front table support. This makes it possible to simply machine workpieces with an edge size of 445 x 445 x 400 mm. The special shape of the table allows the spindle nose to move closer to the table center. Furthermore, it is prepared for the installation of a rotary coupling with 4 ways through the table plate.

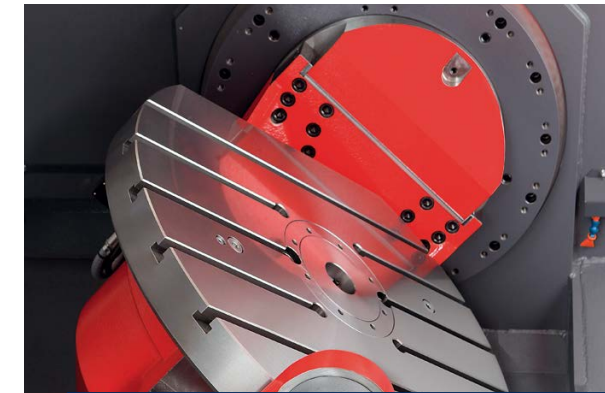

TRAVEL RANGE

With a travel range of $\pm 100^\circ$, the B-axis provides a larger work area than most products from other manufacturers. The C-axis can be infinitely rotated by 360° .

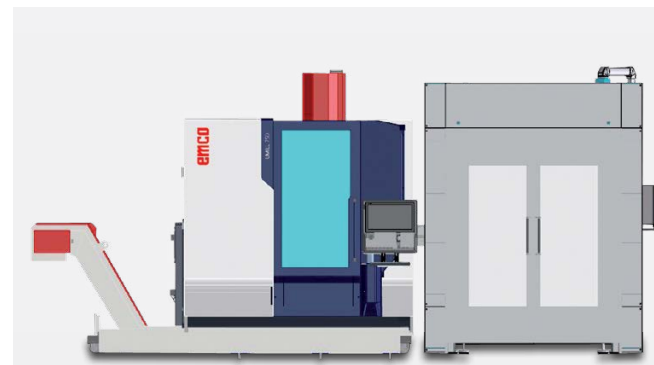

AUTOMATION

Different options, such as an automatic door opening function on the side of the machine, a rotary feedthrough in the table centre etc., make it possible to implement different automation solutions. Thanks to its flexible design, the machine can be loaded automatically from the side or from the front.

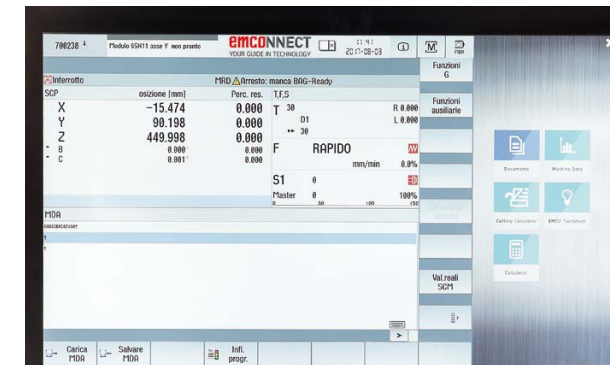

SINUMERIK ONE

The Sinumerik ONE is an universal and flexible CNC system offering free contour programming, milling cycles for complex contours, fast reference point setting with touch probe systems, tilting of the working plane, cylindrical surface machining, 3D tool compensation and fast execution through short block processing times.



HEIDENHAIN TNC 640

The TNC 640 is a compact, adaptable control ideal for 5-axis simultaneous machining. With its flexible operating concept – workshop-oriented programmability in the HEIDENHAIN plain text dialog or external programming – and its scope of performance, it is perfectly suited for EMCO milling centers.

HIGHLIGHTS

- / 5-axis simultaneous machining
- / Top thermostability
- / Top machining precision
- / Modern moving column concept with optimal accessibility
- / Solid swivel-rotary table with torque motors on the C-axis, special worm gear with two drive motors in the B-axis, direct measuring systems, and front support, dimensions of 630 x 500 mm provide high stability and precision
- / Wide swivelling range $\pm 100^\circ$
- / Standard linear scales in X-Y-Z
- / Cutting-edge control technology from Siemens or Heidenhain
- / EMCONNECT available for Sinumerik ONE
- / Extensive options such as 60 / 90 tool stations magazine
- / Optimal chip removal
- / Attractive price-performance ratio
- / Flexible for automation (front or side)
- / Made in the Heart of Europe

NETWORKS ARE CREATED INDIVIDUALLY – OUR SOLUTIONS AS WELL

Staying in touch is not only important for people. Staff, machines and the production environment must also be securely networked with each other to ensure an efficient production process. With EMCONNECT, the machine is optimally equipped for this. In addition, EMCONNECT Digital Services provides innovative online services to optimise machine operation. The machine data form the basis for a wide range of applications. In this way, the user has the status of the machine available at any time and in any place.

Integration into the control

EMCONNECT offers options for situation-dependent operation. Apps can also be used in parallel with the control system. With optimal integration into the NC control system, EMCONNECT complements the NC control with powerful functions for modern control generations (SIEMENS, HEIDENHAIN). The familiar vision of the machine NC control is maintained at all times.

An innovative concept

These powerful apps may be used independently from the control, while in the background the machine is busy in the production process. With only one click, you can change at any moment between numerical control and EMCONNECT. This is possible with the help of an innovative and ergonomic control panel, equipped with a modern 22" multi-touch display, an industrial PC with associated keyboard and HMI hotkeys.

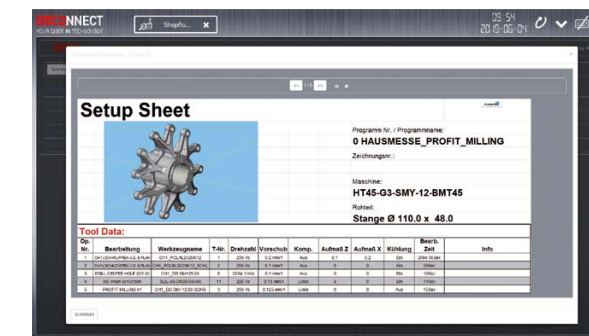

Control panel as central platform

With EMCONNECT, the machine control panel becomes a central platform with access to all necessary applications, data and documents. Remote Support, Web Browser and Remote Desktop offer a wide range of connection options, even outside the direct production environment. The optional OPC UA interface allows data exchange with the IT system environment and interaction with other machines for shop floor automation. In this way, EMCONNECT makes an important contribution to highly efficient machine operation.



Innovative online services

With EMCONNECT Digital Services, all interested users have online access to the current status and evaluations of the machine. Automatic notification in the event of malfunctions or machine stoppages and extended diagnostic options for remote maintenance reduce downtimes and machine downtime to a minimum. Integrated maintenance management supports predictive maintenance based on machine utilisation. Thanks to the continuous development of online services, new functions are always available.

EMCONNECT HIGHLIGHTS AND FUNCTIONS

- Fully networked**
Remote access to office computers, web browsers and online services with all applications and users connected
- Compatible**
Interface for seamless integration into the operating environment
- Structured**
Clear monitoring of the machine state and the production data
- User-friendly**
Intuitive and production-optimized touch operation
- Customized**
Open platform for modular integration of customer-specific applications
- Future-proof**
Continuous extensions as well as easy updates and upgrades

Standard-Apps

| | | |
|--------------------|---------------------|------------------|
| | | |
| Control | Dashboard | Machine Data |
| | | |
| System | Maintenance Manager | Digital Services |
| | | |
| Remote Desktop | Settings | Web Browser |
| | | |
| Remote Support | TeamViewer | Service |
| | | |
| Cutting Calculator | Calculator | Notes |
| | | |
| Backup & Restore | File Import | Documents |
| | | |
| GD&T | EMCO TechSheet | Thread Reference |



Tricalc

Optional

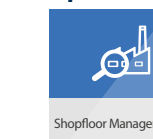

Shopfloor Management

INSTALLATION PLAN

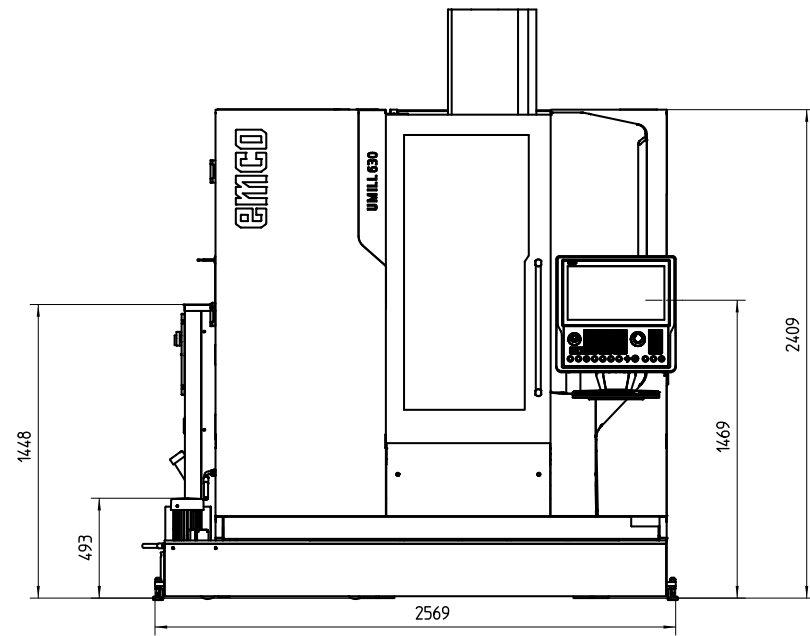

Indications in millimetres

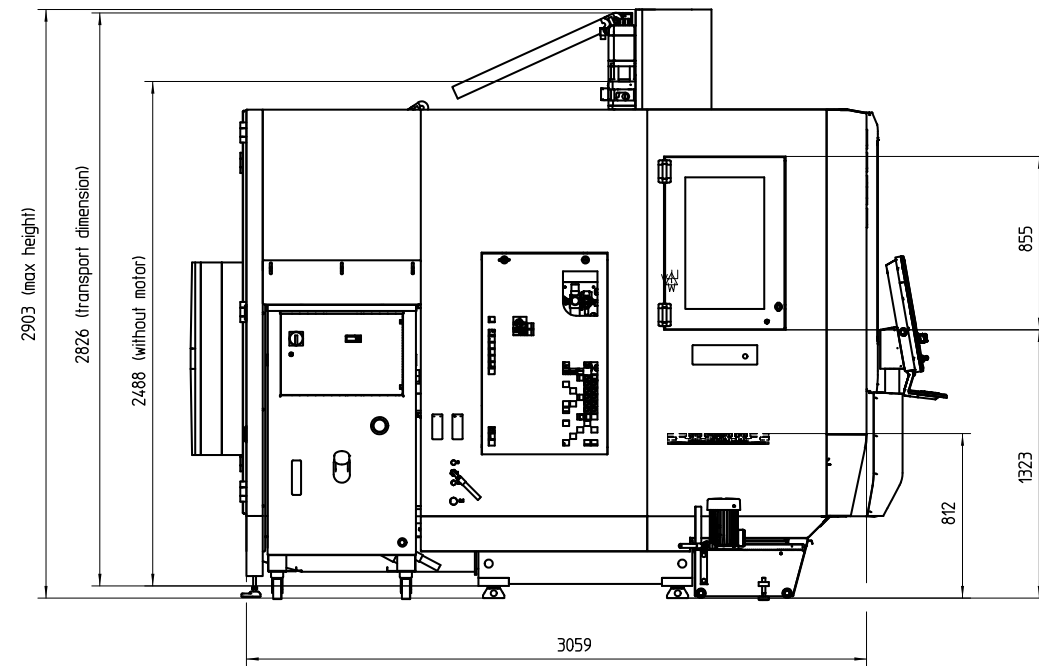

INSTALLATION PLAN

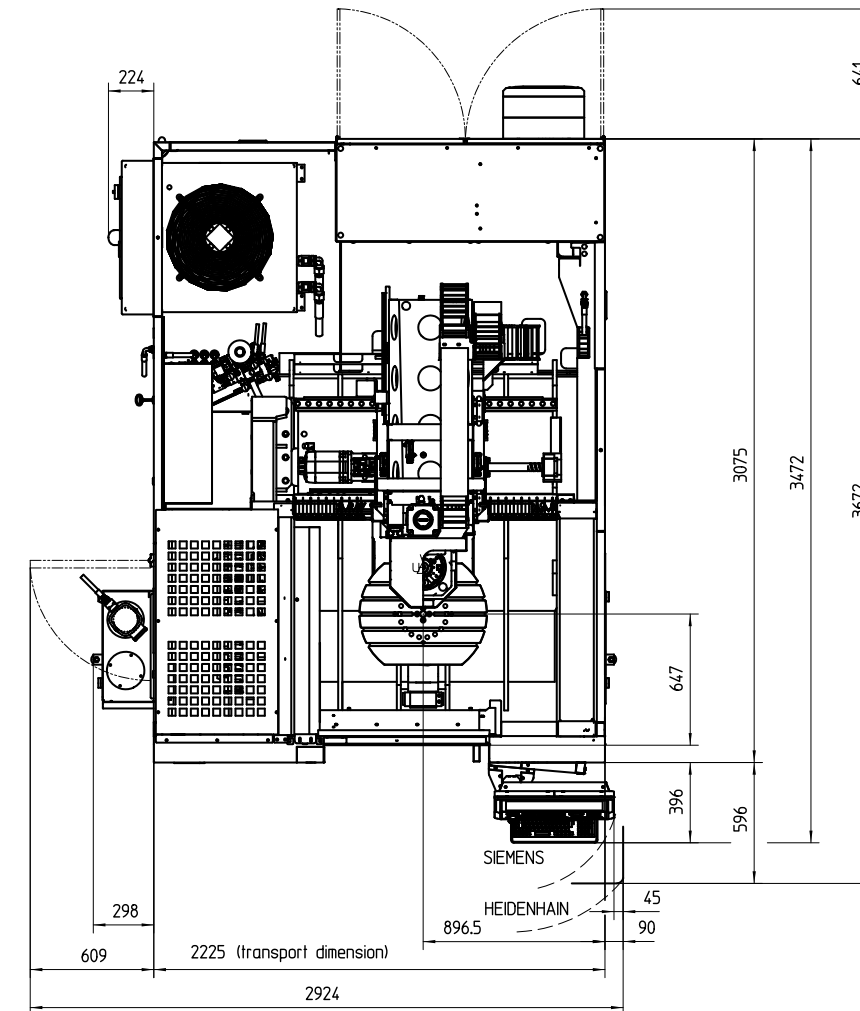

Machine with optional equipment

Indications in millimetres

WORK AREA

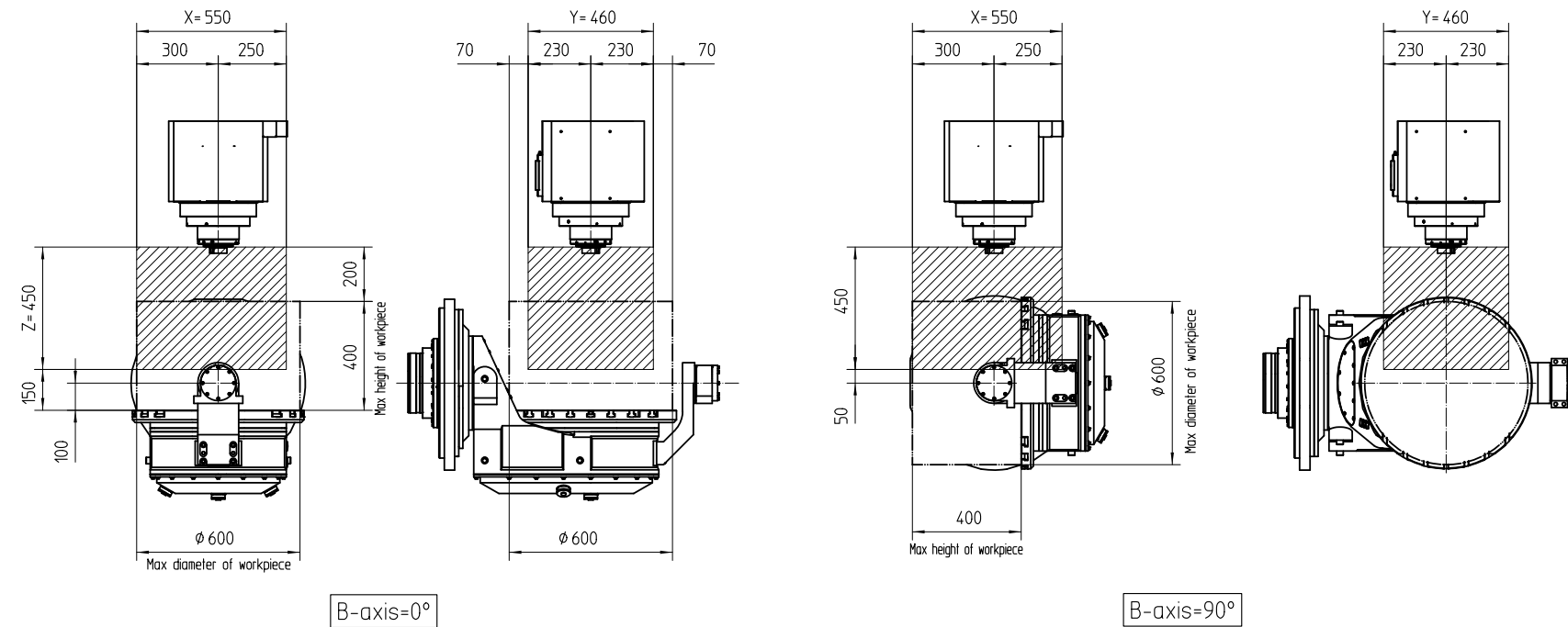

Travel



Workpiece dimensions

Indications in millimetres

TECHNICAL DATA

Travel and tolerances

| | |
|---|--------------|
| Travel in X | 500 + 50 mm |
| Travel in Y | 460 mm |
| Travel in Z | 450 mm |
| Distance spindle nose - table (min. - max. / motor spindle) | 150 / 600 mm |
| Swivel range B-axis | +/- 100° |
| Range of rotation C-axis (rotary table) | 0 - 360° |
| Positioning accuracy P according to VDI 3441 * | 10 μ m |
| Positioning repeatability Ps according to VDI 3441 * | 4 μ m |
| Positioning accuracy B-axis (tilting) | +/- 5 sec. |
| Positioning accuracy C-axis (table) | +/- 5 sec. |

Feed

| | |
|-------------------------------|--------------------|
| Rapid motion speed X-Y-Z axis | 50 m/min |
| Max. rotational speed B-axis | 50 rpm |
| Max. rotational speed C-axis | 100 rpm |
| Max. feed force X-axis | 5000 N |
| Max. feed force Y-axis | 5000 N |
| Max. feed force Z-axis | 5000 N |
| Max. acceleration X-Y-Z axis | 6 m/s ² |

Tilting table

| | |
|---|--------------|
| Clamping area | 630 x 500 mm |
| Table-floor distance | 812 mm |
| Slot number | 5 |
| Distance between two T-slots | 75 mm |
| Groove wide | 14 mm |
| Max. workpiece weight (equally distributed) | 200 kg |

Main spindle (motor spindle)

| | |
|------------------------|------------------------|
| Speed range | 50 - 15000 / 24000 rpm |
| Maximum spindle torque | 110 Nm |
| Maximum spindle power | 26 kW |
| Tool taper | HSK-A63 (ISO40/BT40) |

Tool magazine

| | |
|--|--------------------|
| Number of tool stations | 30 (60/90) |
| Tool changing type | Double arm gripper |
| Tool management | Random |
| Tool changing time (tool-tool) according to VDI 2852 | 3.9 sec. |
| Max. tool diameter | 80 mm |
| Max. tool diameter (without neighbouring tools) | 125 mm |
| Max. tool length | 250 mm |
| Max. tool weight | 8 kg |
| Total tool weight supported by the magazine | 130 kg |

Coolant tank

| | |
|------------------------|----------|
| Tank capacity | 200 l |
| Standard pump pressure | 2 bar |
| Max. capacity at 2 bar | 40 l/min |

Pneumatic supply

| | |
|------------------------|-----------|
| Min. pressure supply | 6 bar |
| Min. capacity required | 250 l/min |

Lubrication

| | |
|-------------------|--------|
| Spindle | Grease |
| Caged roller ways | Grease |
| Ball screws | Grease |

Dimensions

| | |
|--|----------------|
| Total height | 2900 mm |
| Dimensions L x D without chip conveyer | 2570 x 3680 mm |
| Weight | 6800 kg |

* Values measured at 22°C with the machine fixed to the ground.
Machine with linear scales - distance compensation with laser and motor encoders in the turning axis.

beyond standard /

EMCO GmbH / Salzburger Str. 80 / 5400 Hallein-Taxach / Austria / T +43 6245 891-0 / F +43 6245 86965 / info.at@emco-world.com

www.emco-world.com